

Pre-Installation Checklist

- This upgrade will convert the AQR S3 to an AQR S3 Omni and will require Omni specific accessories.
- Power is removed to all equipment in the system.
- All equipment settings and schedules will be lost after the upgrade.
- All safety precautions have been read in the Installation manual.
- Along with some fasteners, the parts shown are included in the box.
- All of the necessary tools and mounting hardware have been gathered (drill, drill bits, Phillips & flathead screwdrivers, level, wire cutters/strippers, mounting anchors and fasteners).
- The Controller will be mounted a maximum of 15' from the AQR S3 and will be mounted a minimum of 6' horizontal distance from the pool or spa.

What's Included:

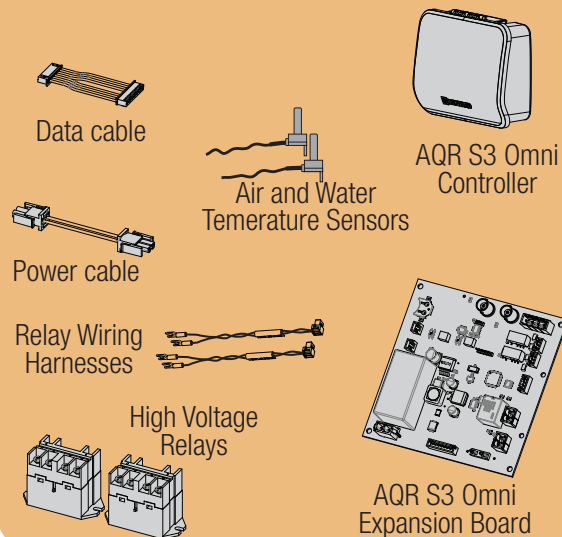

1 Record Current Settings and Wiring Connections

All settings will be lost after upgrading. Before starting the installation, use the Settings Worksheet on page 4 of the Installation Manual to record all current settings, speeds, temperatures, timers, and schedules for all connected pool equipment. This information will be needed when you start the Configuration Wizard (Step 10).



2 Remove Front Panel

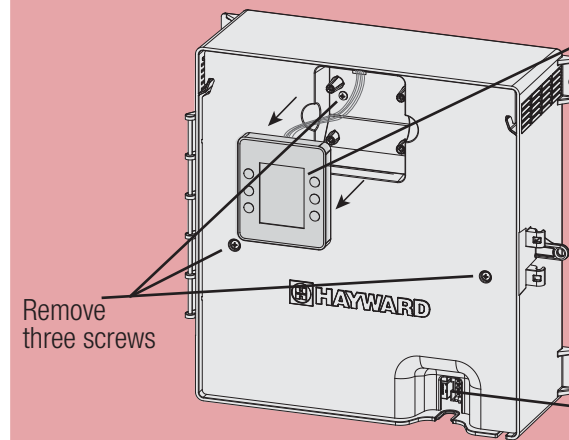

Pull the display away from the panel by grasping it with your hand (no tools required). Then, remove the 3 screws and pull the plastic front panel away from the enclosure.

After the panel is removed, disconnect the display cable and set both the display and panel aside.

3 Install the AQR S3 Omni Expansion Board

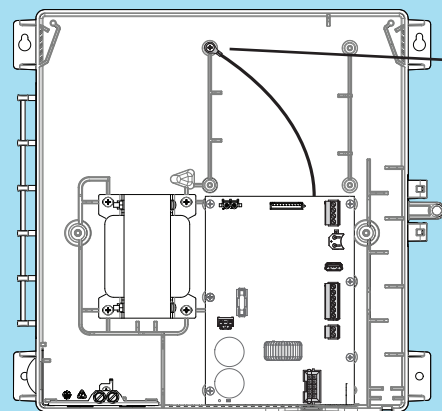

Does your unit have a green ground screw attached here?

If Yes, detach the cable and then install the new Expansion Board and cable as shown below.

If No, install the new Expansion Board as shown below but ignore any references to the cable.

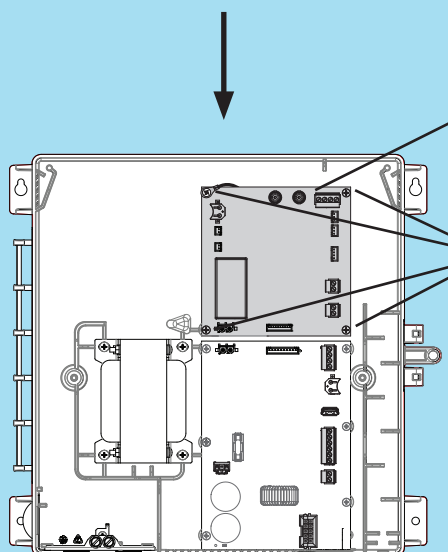
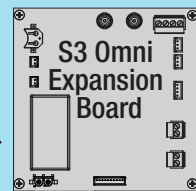

Position the AQR S3 Omni Expansion Board on the 4 mounting points shown. If applicable, position the green cable in the same location where it was removed. Use the four supplied screws to fasten the board and cable to the chassis.

4 Install Power and Data Cables

Plug in the power cable that connects the two boards. Be aware of orientation as the connectors will only insert one way.

Plug in the data cable that connects the two boards. Note that one connector is larger than the other. Be aware of orientation as the connectors will only insert one way.

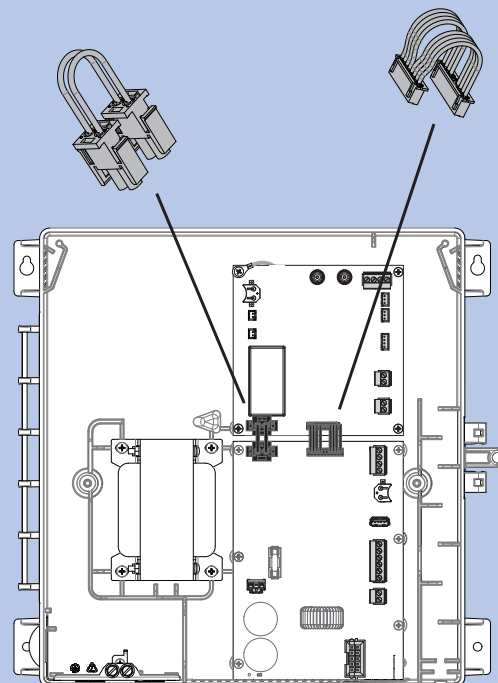

5 Attach Relay Wire Harness and

Relay wire harnesses must be attached to the supplied relays before installation. Locate the harnesses and attach them to the coil side of the relays as shown.

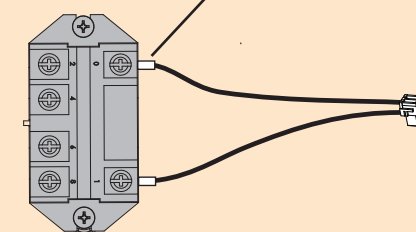
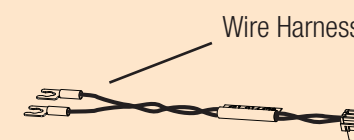
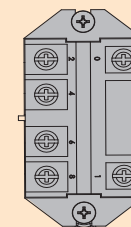

Loosen both coil side relay screws and secure the fork terminal connectors as shown.

6 Install Relays

Use the supplied fasteners to install the relays into the enclosure. After installing the relays, plug the wire harnesses into the AQR S3 Omni Expansion Board as shown.

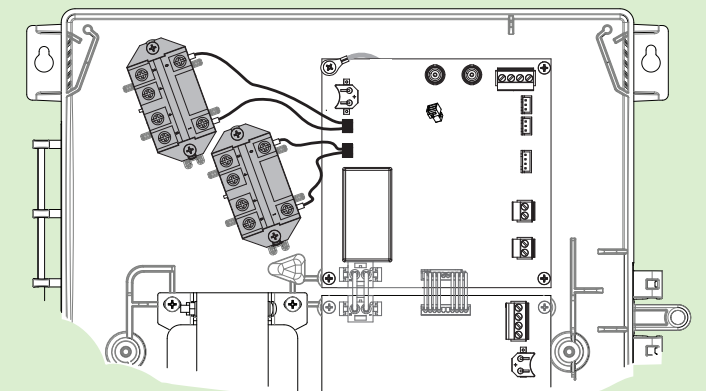

7 Mount Controller

The AQR S3 Omni Controller contains the wifi radio and has a 15 ft cord which must plug into the AQR S3 Omni Expansion Board. When considering a suitable mounting location, refer to the Pre-Installation Checklist on the front of this Quick Start Guide and find a location that will reliably reach the home's router or access point. Allow enough clearance above the enclosure so that the flip door can open fully while mounting at a height that you can easily view and change settings. A mounting template is provided in the Installation manual. To install, screw two appropriate fasteners into the mounting surface at the desired location as shown. Tighten until the bottom of the screw heads are 1/8" off the mounting surface then hang the Controller firmly on the screws.

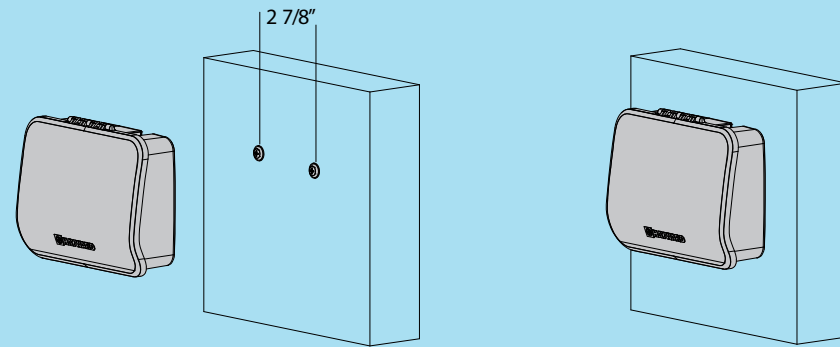

8 Install Sensors

Water Sensor

1. Drill a 3/8" (10mm) diameter hole in the PVC piping and remove all chips and burrs.
2. Insert sensor until O-ring collar sits flush on the hole.
3. Position hose clamp over the sensor and gently tighten until O-ring makes an adequate seal. Do not overtighten.

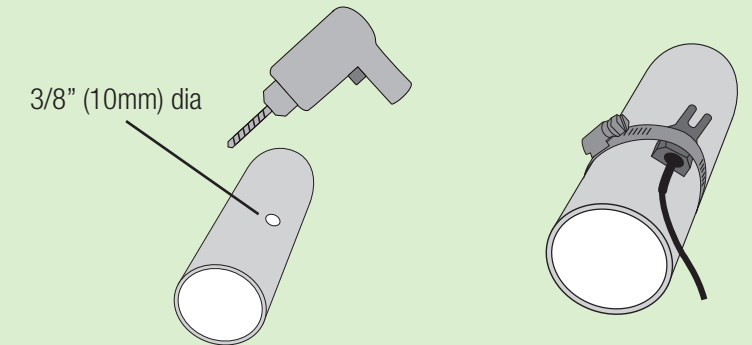

Air Sensor

Mount the air sensor outdoors in a space that is not in direct sunlight or subject to heating/cooling from other sources.

9 Complete Wiring and Fill Out the Connection Table

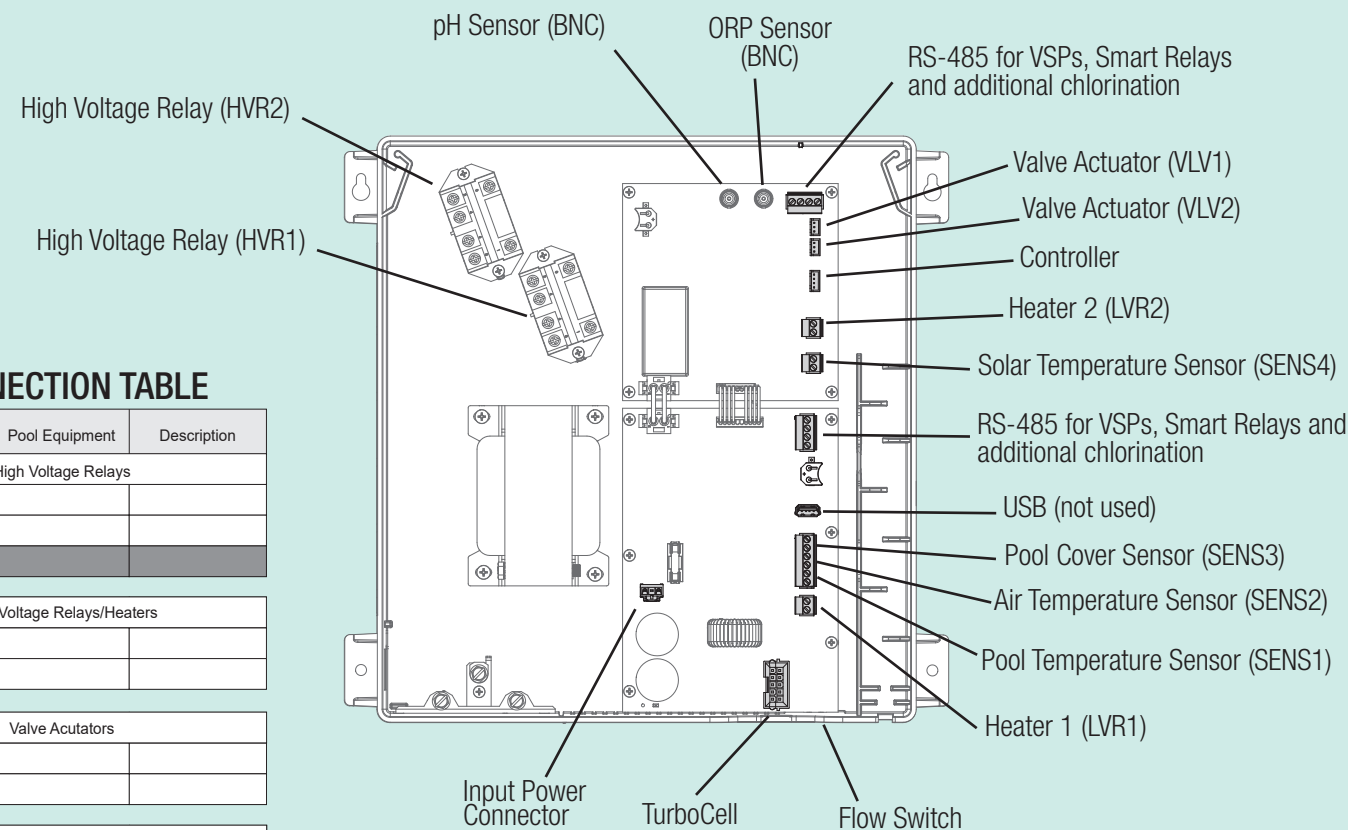

CONNECTION TABLE

Connection	Pool Equipment	Description
High Voltage Relays		
HVR1		
HVR2		
Smart Relay		
Low Voltage Relays/Heaters		
LVR1		
LVR2		
Valve Actuators		
VLV1		
VLV2		
Temperature Sensors		
SENS1 POOL		
SENS2 AIR		
SENS3 COVER		
SENS4 SOLAR		

Optional Smart Relay Purchased Separately

After wiring is completed, prepare the information that will be needed to configure the AQR S3 Omni. This includes identifying each connection and filling out the CONNECTION TABLE. Do not skip this step as this information will be required when starting the Configuration Wizard. To fill out the table, refer to the diagram above. The diagram shows the name of each connection (shown in the table's "Connection" column). Fill in the type of pool equipment that is wired to each "Connection". If no equipment is used, leave the selection blank.

Before Startup

1. All wiring is performed according to NEC and local codes. The AQR S3 Omni is properly grounded.
2. The supplied foam gasket is used to secure access to the low voltage channel.
3. The original S3 display is reconnected and installed. The deadfront panel has been reinstalled.

10 Start Up, Configuration and Registration

Turn on power to the AQR S3 Omni. The unit will power on and prompt you to begin configuration (see below). The Configuration Wizard will ask general questions related to your pool/spa and specific questions about connected pool equipment. Configuring the AQR S3 Omni requires knowledge of all of the connected pool equipment. Refer to the Connection Table (Step 8) and your Settings Worksheet (Step 1) while progressing through the Configuration Wizard.

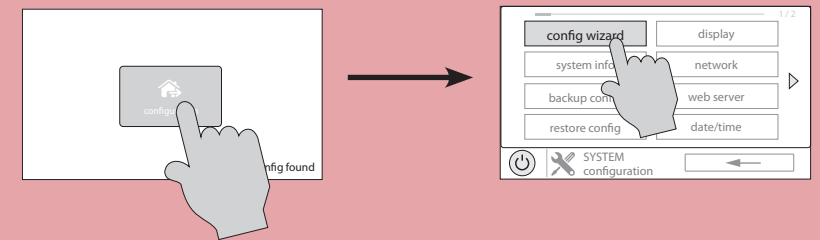

Find your MSP ID

After configuration, the AQR S3 Omni can be controlled from your mobile device. You must first create an account and register your AQR S3 Omni using Hayward's "OmniLogic" app available in your device's app store. During registration, you'll be asked for the AQR S3 Omni's MSP ID to link to your account. To find the MSP ID, follow the steps below using the touchscreen Controller.

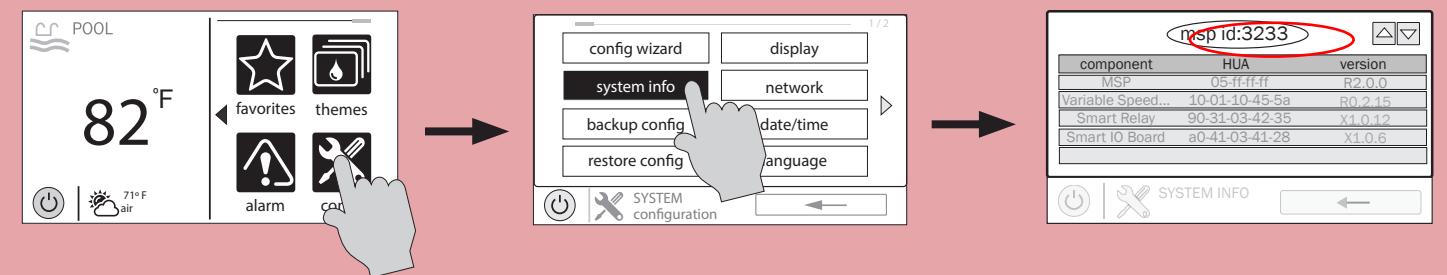

Create an OmniLogic Account using OmniLogic App on your mobile device

Download the "OmniLogic" app from your mobile app store. Launch the app and select "Don't have an account?" at the bottom of the screen. Follow the prompts until your account is setup.

After setup, select "Add New Site" to link the AQR S3 Omni to your account. Input your MSP ID and fill out the remaining information.

With the AQR S3 Omni now linked to your account, you can control your pool remotely from any PC, laptop, or mobile device. For computers, go to haywardomni.com and log in to your account. For mobile devices, download the OmniLogic app and then log in to your account.

