



# HydroRite

2" Commercial UV/Ozone Sanitizing System

## Owner's Manual



**Contents**

- Safety Instructions.....1
- Before you Begin.....3
- Installation.....4
- Operation.....8
- Maintenance.....12
- FAQs.....14
- Troubleshooting.....15
- Replacement Parts.....17



Certified to NSF/ANSI Standard 50

HYR2CSC-UVO

**REGISTER NOW**  
*to extend your*  
**WARRANTY**

*see back of manual for details*

Hayward Pool Products  
620 Division Street, Elizabeth NJ 07207  
Phone (908)-355-7995  
[www.hayward.com](http://www.hayward.com)



# HAYWARD®

## **IMPORTANT SAFETY INSTRUCTIONS**

When installing and using this electrical equipment, basic safety precautions should always be followed, including the following:

### **READ AND FOLLOW ALL INSTRUCTIONS**

This product should be installed by a professional service technician or similar person who is qualified in electrical equipment installation. Improper installation and/or operation could cause serious personal injury, property damage or death. Improper installation and/or operation will void the warranty.

- The device must be connected only to a supply circuit that is protected by a Ground Fault Circuit Interrupter (GFCI). FAILURE TO CONNECT THIS DEVICE TO A GFCI SUPPLY CIRCUIT COULD RESULT IN ELECTRICAL SHOCK CAUSING SERIOUS BODILY INJURY, INCLUDING DEATH.
- WARNING - Disconnect all AC power during installation.
- CAUTION - To prevent possible fire or electrical shock, use only replacement lamp specified by the manufacturer.
- A bonding lug is provided on the external surface. To reduce the risk of electric shock, connect the local common bonding grid in the area of the swimming pool, spa, or hot tub to these terminals with an insulated or bare copper conductor not smaller than 8 AWG US / 6 AWG Canada.
- Replace damaged cords immediately.
- Lamps and quartz sleeves are made of glass and are extremely delicate. Care should be taken when handling or replacing these components. Wear cotton gloves when handling lamps or sleeves. Hold bulbs by the ends only. Never touch the glass with bare hands. Wipe any fingerprints from lamps and sleeves with rubbing alcohol.
- CAUTION - this device is for swimming pool use only. Do not use this device for potable (drinking) water sanitization.
- DANGER - ULTRAVIOLET RADIATION. Disconnect Power Before Replacing Lamp .
- This device contains an ultraviolet lamp that can cause discomfort, irritation and damage to the eyes if viewing occurs while device is in operation. Prolonged exposure to the eyes can cause serious injury to the eyes, including blindness. DO NOT VIEW UV LAMP WHILE THE DEVICE IS IN OPERATION.
- **SAVE THESE INSTRUCTIONS**



**Danger - Acid Wash tank will be filled with corrosive acid:**

- Poison - may be fatal if swallowed. Causes severe burns. Vapor harmful.
- Keep away from children and pets.
- Filling and service to be performed by pool service professional only.
- Read all manufacturer cautions and directions before use.

**To homeowners and users:**

- This tank contains acid that is dangerous to handle, and can harm people and equipment if not properly contained, transported, poured, stored, and dispensed.
- Perform safety check before entering water each day! Check the pool chemistry and pool controller alarm status prior to entering the pool or spa. Resolve any issues prior to entering the water.
- Keep equipment maintained! The system should be inspected annually.
- Don't open the lid! Slightly tip tank to check for liquid level.

**To service personnel:**

- Perform dilution by adding water to tank - then adding the acid. To prevent violent boiling and splashing, always add acid to water, and do so slowly.
- Always dilute acid according to manufacturer's specifications.
- Always follow chemical manufacturers' directions and warnings.
- Follow the installation checklist to verify proper operation upon installation and at the beginning of each pool season.

Safety precautions are required to ensure that an equipment malfunction is detected. Great care must be taken when installing, maintaining and operating acid pump feed systems.

**NOTICE TO USER:** This pest control product is to be used only in accordance with the directions on the label. It is an offence under the Pest Control Products Act to use this product in a way that is inconsistent with the directions on the label. The user assumes the risk to persons or property that arises from any such use of this product.

This product has met the requirements of NSF/ANSI 50, Annex H.1: Disinfection Efficacy for the  $\geq 3$  log reduction of *Enterococcus faecium* [ATCC #6569] and *Pseudomonas aeruginosa* [ATCC #27313]. This product is intended for supplemental disinfection and should be used with registered or approved disinfection chemicals to impart residual concentrations in accordance with state and local regulations.



## Before you Begin

The Hayward HydroRite™ HYR2CSC-UVO is designed for use in commercial swimming pools and must not be used in potable (drinking) water installations. Use of this product in applications other than swimming pools will void your warranty and could be harmful to your health or the health of others.

### How the Hayward HydroRite Works

The Hayward HydroRite contains a high intensity electrically operated Ultraviolet (UV) lamp which is located inside the unit's wet chamber. The UV lamp emits light at two separate wavelengths within the UV spectrum; 254 nm and 185 nm. The 254 nm wavelength is called the "germicidal" wavelength. This wavelength is capable of inactivating a wide array of microorganisms such as bacteria, viruses, protozoa (e.g. Cryptosporidium and Giardia), algae spores and other single vesseled waterborne microbes. The 254 nm UV light alters the DNA and RNA of the microorganisms rendering them incapable of infection. The 185 nm wavelength, on the other hand, is called the "ozone generating" wavelength and is responsible for converting oxygen contained in the quartz sleeve area, into ozone. The ozone is introduced into the water stream using a venturi. Ozone, a strong oxidizer and bactericide, works together with the UV to oxidize bather waste and inactivate microorganisms utilizing a process known as "advanced-oxidation".

### Specifications

**Input Power:** 120VAC, 60Hz  
**HydroRite Power Consumption:** 2.5A  
**Venturi Booster Pump Power Consumption:** 13.8A  
**Volume of Vessel:** .75 gallon  
**Number of bulbs:** 3

**Plumbing Diameter:** 2 inch  
**Operating Flow Range:** 32-75 gpm  
**Maximum Operating Pressure:** 50 psi  
**Maximum Flow Rate:** 75 gpm

### Sizing

Sizing your pool should be based on turnover time and local codes. For 6 hour turnover at max flow rate, the HYR2CSC-UVO is rated to treat 27,000 gallons. For 8 hour turnover, it can treat 36,000 gallons. Determine your turnover time and size accordingly. When using more than one HydroRite, always plumb them in parallel. Rated performance relies on full water flow passing through the vessel.

### Input Power

Both the HydroRite controller and the venturi booster pump require 120VAC GFCI protected receptacles. Note that the venturi booster pump requires a 20A circuit.

### What's Included

The HydroRite system contains the following components:

- HydroRite Controller with cables
- Booster Pump Junction Box with cables
- Venturi Booster Pump
- Venturi Manifold
- Diverter Assembly
- Venturi Hose
- Vessel
- Ozone Producing UV Lamps
- Gloves for handling the UV Lamps
- Flow Switch

### Tools Needed

- Saw or PVC pipe cutter
- PVC glue
- 6 mounting screws/bolts for fastening HydroRite controller to mounting surface
- 4 mounting screws/bolts for fastening HydroRite vessel to mounting surface
- Screwdriver/Nutdriver for mounting fasteners
- Philips head screwdriver for vessel cap

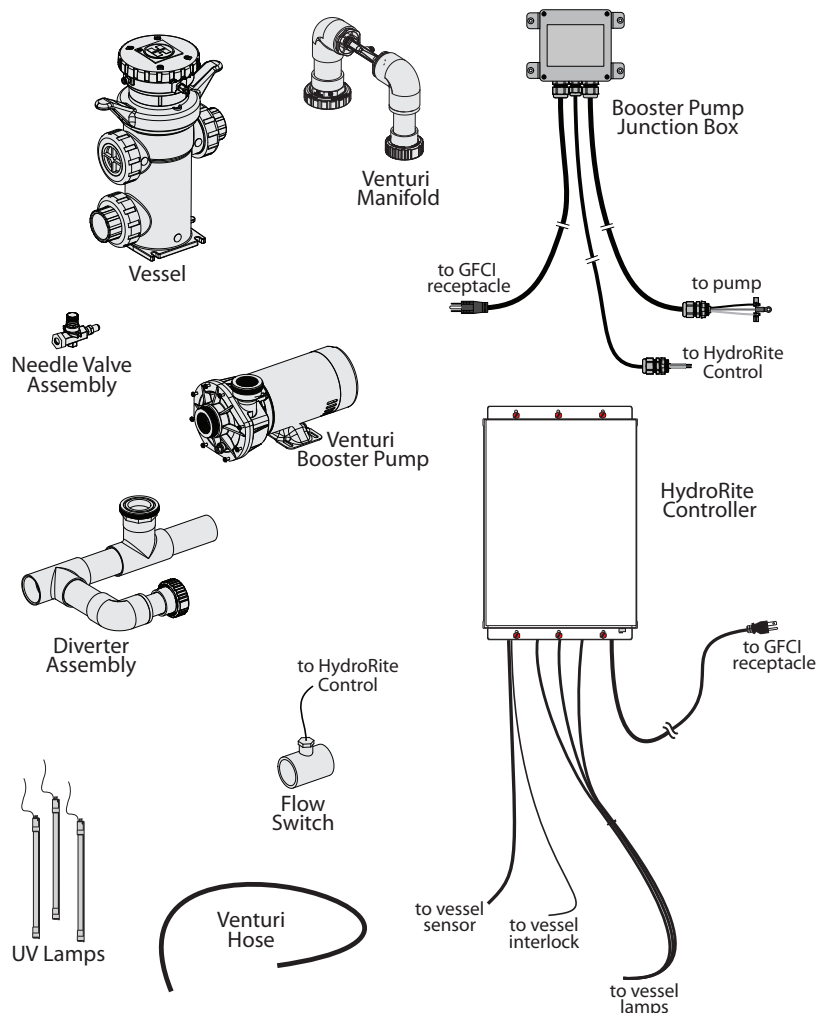

## Installation

Before starting your installation, you **MUST** read this manual in its entirety in order to install your unit in a safe manner. Note that a few moments spent becoming familiar with the HydroRite unit and its installation may save a great deal of time (and expense) later. If you have any questions that are unanswered when you have completed the reading of this manual, contact your supplier or Hayward. Remove power to the pool filter pump before starting this installation.

**WARNING:** Determine that the flow rate of your pool does not exceed the maximum specified.

### Overview

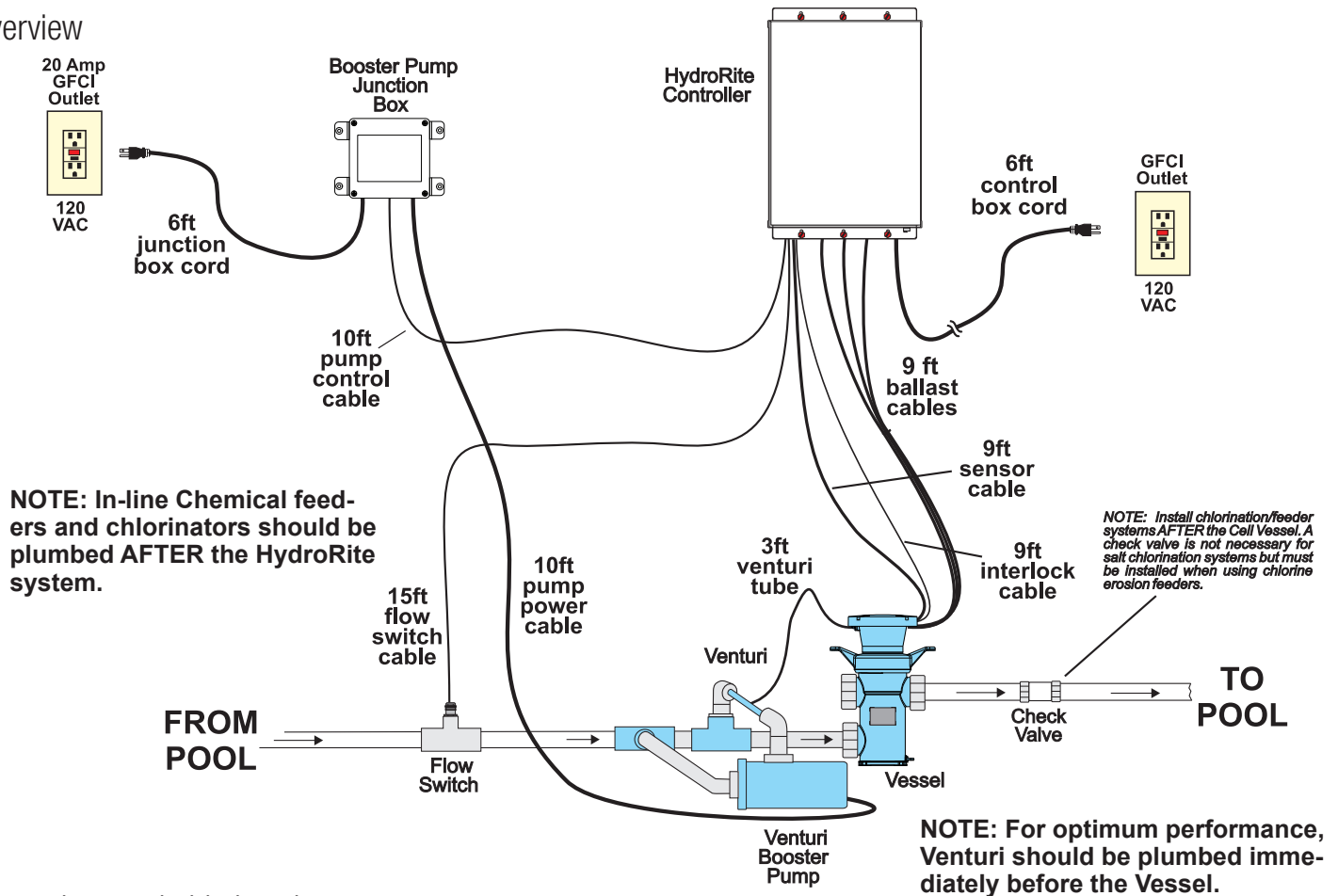

### Determine a suitable location

Refer to the above diagram. Installation of HydroRite system requires mounting the controller, junction box and vessel which all use fixed length cables. The included booster pump, vessel, venturi and flow switch must be plumbed on the return side of the filter pump as shown. Consider the length of all cables as well as access limitations at the pool pad before starting the installation. Note also that the HydroRite vessel must be mounted at least 10 ft. from the pool and both the junction box and the controller must be mounted a minimum of 6 ft. horizontal distance (or more, if local codes require) from the pool. Installation must be performed in accordance with local and NEC code.

Heaters can be installed before or after the HydroRite system but water temperature must not exceed 104° at the entrance of the Vessel. If locating a heater before the HydroRite Vessel, please note that water temperatures at the exit of a heater can be substantially higher than the current heat setting.

When considering a mounting location for the controller and the booster pump, note that both use 6 ft. long power cords intended for GFCI receptacles. The controller is designed to mount vertically on a flat surface with the cables facing downward. Because the enclosure also acts as a heat sink (disperses heat from inside the box), it is important not to block the four sides of the controller. Do not mount the controller inside a panel or tightly enclosed area. If the supply or vessel cords are damaged, they must be replaced by the manufacturer, its service agent or similarly qualified persons in order to avoid a hazard. Refer to the diagram above for lengths of other cords and the venturi tube.

### Mounting the Controller

After ensuring that the controller's cables can reach their destinations, mount the controller to the intended surface. Use proper mounting hardware given the size and weight of the unit. The controller's mounting brackets require a total of 6 mounting bolts to fasten the controller to the mounting surface.



## Mounting the Booster Pump Junction Box

Four "ears" are included with the junction box and mount from the back. Fasten all four ears with a Phillips head screwdriver. With the ears attached, the junction box can now be mounted on the intended surface using appropriate hardware.

## Securing the Vessel

The vessel should be secured to a concrete or wood base. Four mounting holes are located in the mounting base of the unit that accommodates 1/4 inch diameter bolts to mount the HydroRite unit in place. FAILURE TO PROPERLY SECURE THE UNIT MAY CAUSE NOISE DUE TO VIBRATION CAUSED BY WATER PASSING THROUGH THE WET CHAMBER. Secure the vessel using bolts and anchors (not supplied) where necessary and appropriate for your installation.

## Plumbing

Refer to the overview diagram on 4 as well as the plumbing diagram below. All of the HydroRite's components are plumbed in the pool's circulation system on the return side at the end of the installed equipment. Only chemical feeders and chlorinators should be plumbed after the HydroRite equipment (see Chemical Sensing, Chlorination and Chemical Feed Systems). Pre-assembled piping is included to aid in the plumbing of the venturi booster pump, venturi and vessel. The diagram below shows these pieces assembled in the desired configuration. Determine a suitable installation location at the pool pad for this assembly and consider that the vessel's base must be secured. Read all of the information below before gluing pipes.

- 1 Hand fasten unions using the supplied O-Rings.
- 2 Glue pipe to unions. Hand fasten unions to vessel using the supplied orange gaskets.
- 3 Glue desired length of pipe between diverter assembly and the flow switch.
- 4 Glue piping from filter pump to flow switch. There must be at least 12" of straight run before the flow switch.
- 5 Thread the needle valve assembly to the venturi manifold. Connect the venturi hose.

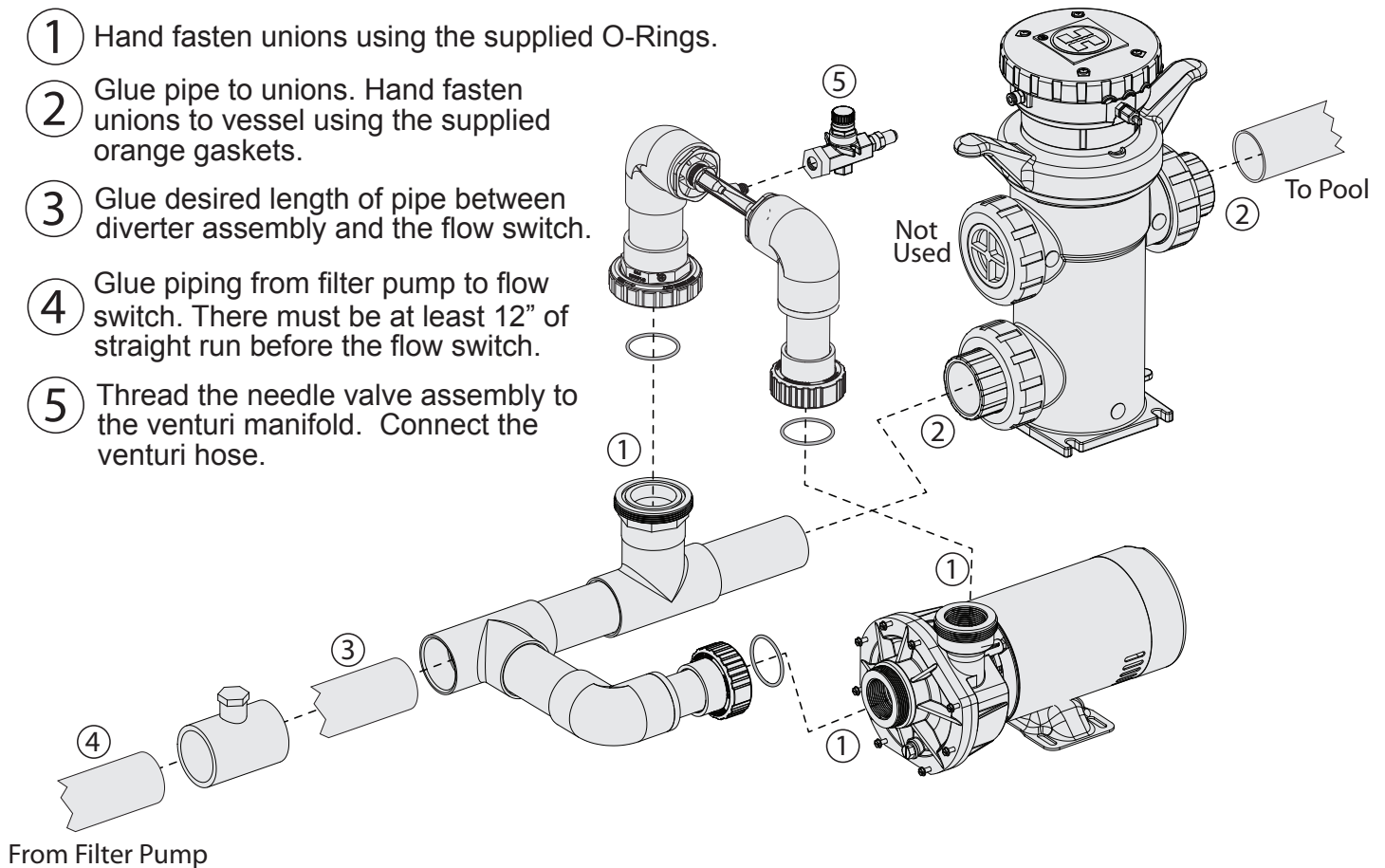

## Plumbing the Flow Switch

The flow switch is a safety device that ensures that water is flowing through the vessel while the HydroRite is operating. The flow switch must be plumbed BEFORE the HydroRite plumbing assembly. Failure to properly install the flow switch can result in damage to the pool's equipment. When installing the flow switch, ensure the following:

- There must be at least a 12" (30cm) straight pipe run before (upstream) the flow switch.
- To ensure proper operation, verify that the arrow on the flow switch points in the direction of water flow.
- If water will be diverted around the HydroRite vessel, valves must be located UPSTREAM of the flow switch (water must not be allowed to flow through the vessel without flowing through the flow switch).



## Plumbing the Vessel

The HydroRite vessel comes with union nuts and tails pre-assembled on the housing. Remove the Inlet and Outlet nuts and note the orientation of the orange gaskets when removing union tails. These will need to be put back together after gluing the union tails to the pool piping.

After cutting pipe to length (or using supplied length on inlet), slide one union nut onto the cut pipe and glue the gray tail piece to the pipe end. Repeat for the other pipe. Thread the union nuts onto the vessel and handtighten both unions. **DO NOT OVERTIGHTEN. OVERTIGHTENING WILL BREAK THE UNION NUTS.**

To avoid breakage, piping should be supported and should not rest solely upon the unions. Installation of valves on the inlet and outlet lines attached to the HydroRite device is recommended and required if automatic cleaning will be used. If the HydroRite unit is located with any portion of the unit below the surface of waterline, then **VALVES ARE MANDATORY**, so you may winterize or remove the device without draining your pool. Failure to use valves where any portion of the device is below the waterline will not allow the device to be properly drained which could lead to cracking of the unit if any retained water freezes.

## Chemical Sensing, Chlorination and Chemical Feed Systems

Care must be taken to prevent exposure of the cell vessel to high concentrations of chlorine or other chemicals. All in-line chlorine systems and chemical feeders must be installed **AFTER** the cell vessel (downstream).

If using a chlorine erosion feeder or other chemical feeders, install a check valve (see diagram on 4) to isolate the cell vessel from the feeder preventing back-feeding when the filter pump is off. For salt chlorinators, a check valve is not necessary because those systems stop producing chlorine when the filter pump is off.

If chemical sensing is required, locate the sensing sample lines **BEFORE** the HydroRite vessel.

**After plumbing is complete, run the filter pump and check for leaks in the HydroRite system. Address any concerns before making electrical connections.**

## Vessel Connections and Wiring

Do not plug in 120v electrical power cords until all wiring is complete. To gain access to vessel connectors, remove the four screws securing the large vessel cap (cover). Remove the cap. Make your connections (described below) and route the cables through an appropriately sized cutout. The cap can then be replaced and secured. Refer to the information below, the adjacent diagram and the diagram on the top of page 7 for connection locations.

### 1. Venturi Tube

Insert the 3 ft. venturi tube into the ozone manifold as shown in the diagram on page 7. Note that the tube can be cut to a shorter length to aid in installation. To avoid leaks, be sure to make a clean square cut so that the tube fits into the ozone manifold properly. The venturi tube is made of a specific material suitable for its purpose. If replacing the tube, call Hayward Technical Support at 908-355-7995.

### 2. Sensor Cable

Screw the sensor cable into the center of the vessel top as shown in the diagram on page 7. This connection should be made first because access will be limited after the Ballast Cables are installed. **DO NOT OVERTIGHTEN.** Route the cable through the appropriate cutout.

### 3. Ballast Cables and UV Lamps

**DO NOT TOUCH THE UV LAMP WITH YOUR BARE HANDS.** Gloves are included with HydroRite and must be used when handling the lamp. There are three ballast cables from the controller that connect to UV lamps (packaged separately). These cables must be connected to the lamps **BEFORE** inserting the lamps into the vessel. Because of the different size tabs on the lamps, it will only insert one way into the vessel. After fully seating the lamps into the vessel, twist the lamp/cable clockwise about 1/8 turn to lock it into place then route the ballast cables through the appropriate cutouts.

### 4. Interlock Cable

The Interlock prevents lamp operation when the cap is removed. The two conductor interlock cable attaches to the square connector at the end of the pigtail shown above. Find the appropriate cutout and route the wire through. See diagram on page 7.

### 5. Ozone Tubes

Insert each UV lamp's ozone tube into the back of the ozone manifold as shown in the diagram on page 7. Note that ozone tubes can be cut to a shorter length for easier routing.

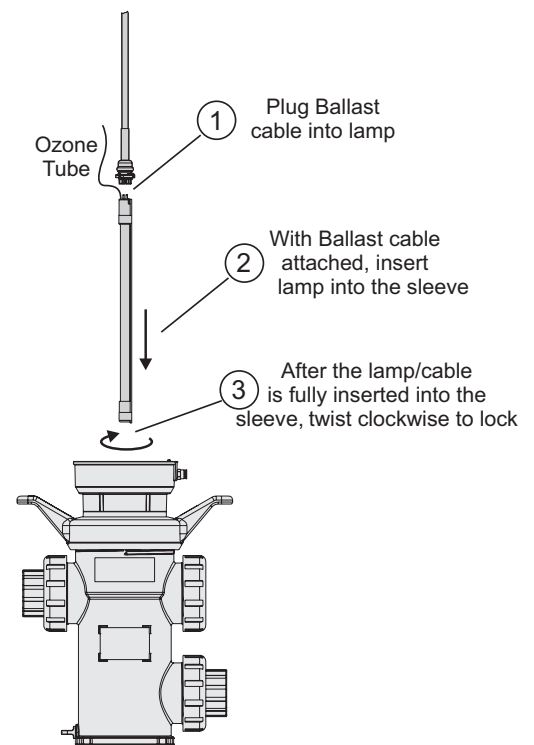



# HAYWARD®

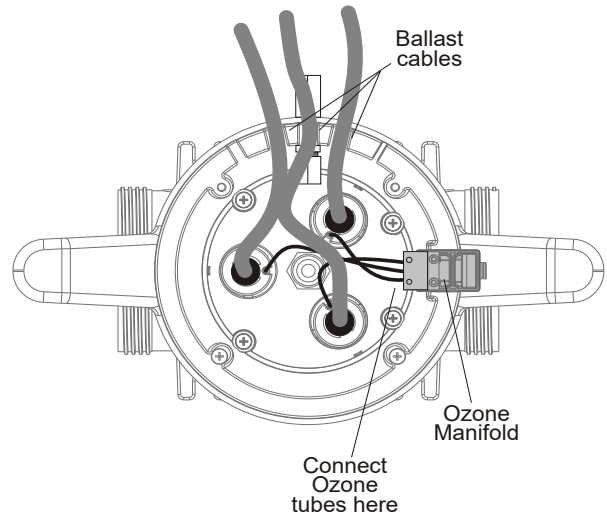
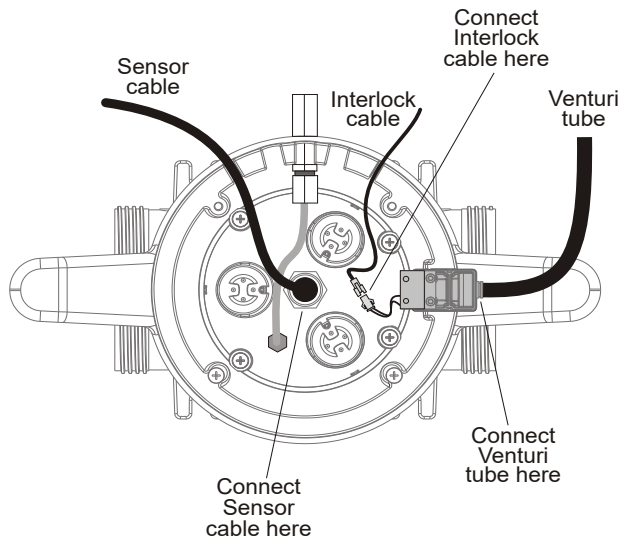

## Venturi Booster Pump Wiring

Remove the single fastener securing the venturi booster pump's wiring cover. The heavy gauge cable coming out of the booster pump junction box must be wired to the venturi booster pump as shown. A strain relief fastener is loosely attached to the cable and needs to be secured as shown.

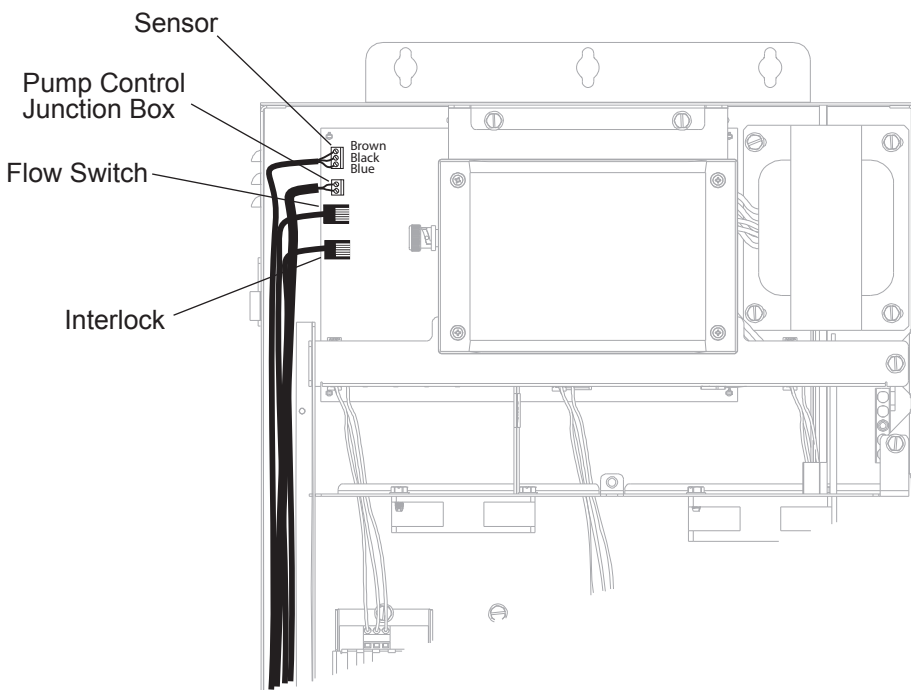
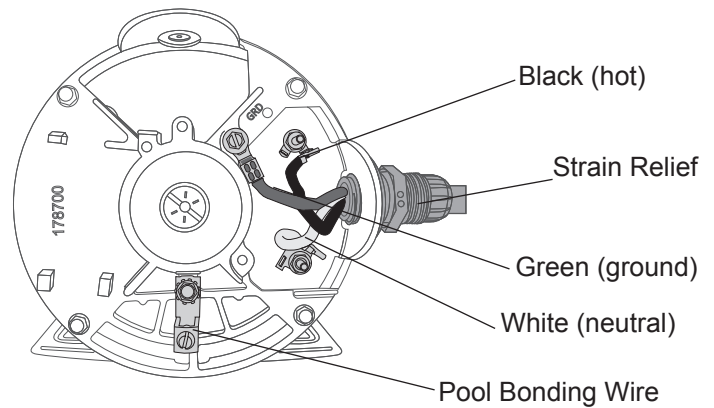

## Controller Connections

Remove the front panel on the HydroRite controller to expose wiring connections. Make the connections according to the adjacent diagram. Be sure to route all four cables through a knockout on the left (low voltage) side of the enclosure.

### Flow Switch

Plug the RJ-45 connector from the flow switch into the socket on the main board as shown.

### Interlock Cable

Like the flow switch, the interlock cable uses an RJ-45 connector that plugs into the main board as shown.

### Venturi Booster Pump Junction Box

Fasten the two conductor cable to the screw terminals as shown.

### Sensor Cable

The three conductor sensor cable is already attached to the three position screw terminal block as shown.





### Input Power

HydroRite uses a linecord for input power and must be plugged into a 120V 50/60hz GFCI protected outlet. NOTE: Should the electrical power cord of your HydroRite unit become frayed or damaged, unplug it from the power receptacle and contact Hayward. USE OF A FRAYED OR DAMAGED POWER CORD COULD RESULT IN ELECTRICAL SHOCK CAUSING SERIOUS BODILY INJURY, INCLUDING DEATH.

After all connections have been made, replace the controller's front panel.

## Pool Preparation

### Water Preparation

Check local codes before adding any recommended chemicals.

Now that HydroRite has been plumbed and wired, start the pool filter pump and verify that there are no leaks at the vessel. Before starting operation of HydroRite, the pool's chemistry should be checked and adjusted to the recommended levels shown below. If opening the pool for the first time of the season, sanitize and balance the pool BEFORE operating HydroRite.

CHEMICAL	IDEAL LEVELS
Free Chlorine	1.0 to 3.0 ppm
Cyanuric Acid	20 to 30 ppm (outdoor) 0 ppm (indoor)
pH	7.2 to 7.8
Total Alkalinity	80 to 120 ppm
Calcium Hardness	200 to 400 ppm
Iron	< 0.3 ppm (0.3 mg/L)
Manganese	< 0.05 ppm (0.05 mg/L)

## Operation

With the pool water balanced and the installation complete, both the HydroRite and the junction box can be plugged into a GFCI protected outlet to begin operation.

### Start Up Calibration

To begin operation, push the System Power button. At initial power up, the HydroRite will calibrate the new UV bulbs. Calibration takes 30 minutes and requires uninterrupted operation of the pool filter pump.

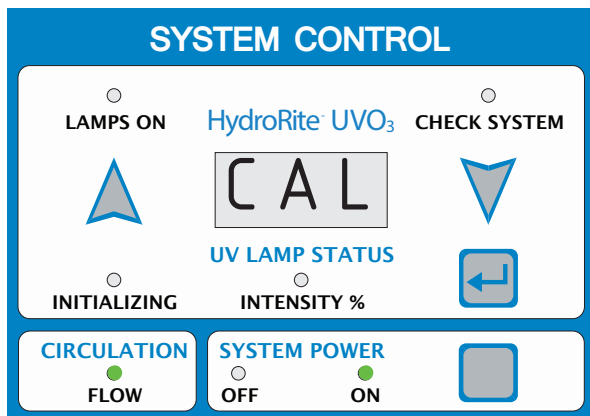

During calibration, the HydroRite LED display will cycle back and forth between "CAL" and the amount of time remaining to complete calibration. At the end of the calibration period, the HydroRite will either display a "P" for pass or "F" for fail (refer to Troubleshooting for failed calibration).

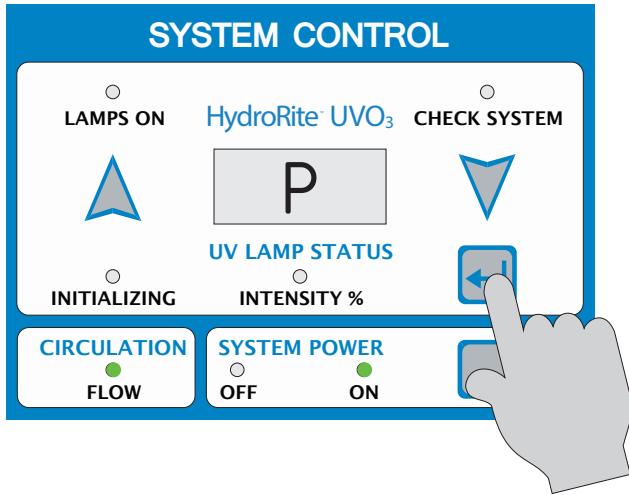

While the “P” is displayed, push the Enter key on the keypad. The HydroRite will go into normal operation and the UV lamp status (Intensity %) will be shown in the display. The HydroRite should remain powered at all times; the UV bulbs will go on and off with the pool filter pump.

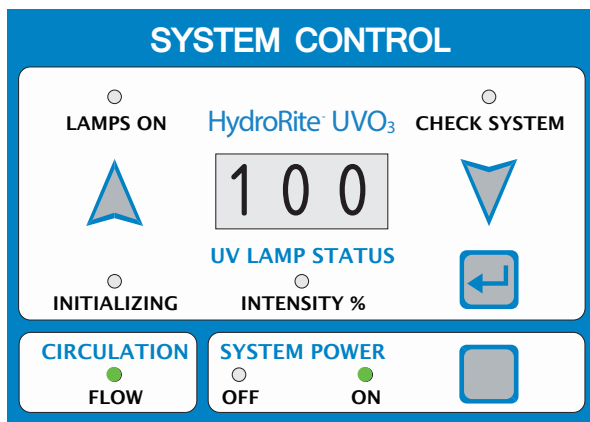

The Intensity will start out at approximately 100% and will slowly decline over time. When the UV lamp status reaches 70%, an internal alarm will be displayed and will require that the HydroRite be cleaned. Refer to Maintenance section for cleaning information. After cleaning, the HydroRite should return a higher Intensity value and continue normal operation. Over time, additional cleanings may be required and eventual bulb replacement will be necessary.

## Operation

After the lamps have been calibrated, the HydroRite will automatically start to sanitize. For normal day to day operation, there are no settings or user input required. System Power should be left ON. The HydroRite senses water flow and will sanitize only when the pool filter pump is running.

### Lamp Intensity

Lamp intensity is displayed on a 0-100% scale. After initial calibration, lamp intensity will be set to 100% and will slowly decline with use. The HydroRite will automatically monitor the health of the lamps by briefly turning off the venturi booster pump every 2 hours and taking a reading. This procedure takes about 60 seconds to perform. To manually initiate a UV measurement at anytime, hold the up and down arrows simultaneously for 4 seconds.

When lamp intensity drops to 70% or lower, the HydroRite will display “SyS Err” and initiate an audible alarm, prompting the user to rectify the condition. The following reasons can cause low lamp intensity:

- 1 or more lamps are burnt out
- Lamps have degraded over time (13,000 hour life)
- 1 or more ballast is bad (look at LED light on ballast)
- Glass sleeves around lamps are dirty (see 12 for cleaning instructions)



## Menu

The HydroRite offers a menu of functions that can be accessed by the user. To enter the menu, press and hold the hidden "Rite" button for 2 seconds. Use the UP and DOWN arrows to navigate through the list of available functions (shown below) and use the ENTER button to execute:

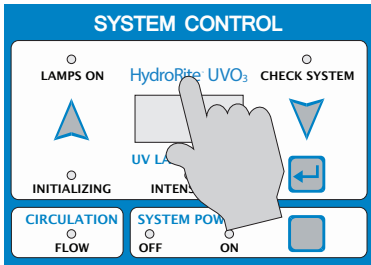

- CLr (Clear) - Use this function to clear errors and alarms.
- CAL (Calibrate) - Used only when new lamps have been installed. Use the ENTER button to start calibration or the hidden "Rite" button to cancel. Refer to Manual Calibration below for specific instructions.
- TS1 (Test) - Will show the current UV sensor reading in mV (millivolts)
- dSp (Display) - Shows the last calibration reading in mV (millivolts)
- Aud (Audible) - Enable or Disable internal beeper (beeper can not be disabled for low lamp intensity)
- run (Runtime Counter) - Shows hours of run time on lamps

## Manual Calibration

**IMPORTANT: Calibration should only take place after lamps have been replaced. Never calibrate during normal operation or after cleaning the quartz sleeves.** If the UV bulbs are replaced, calibration must be initiated manually. Calibration takes 30 minutes and requires uninterrupted operation of the pool filter pump. To calibrate after installing new bulbs, follow the procedure below.

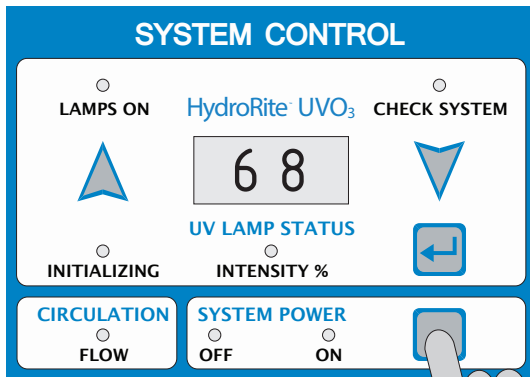

1) Turn off the HydroRite using the Power button.

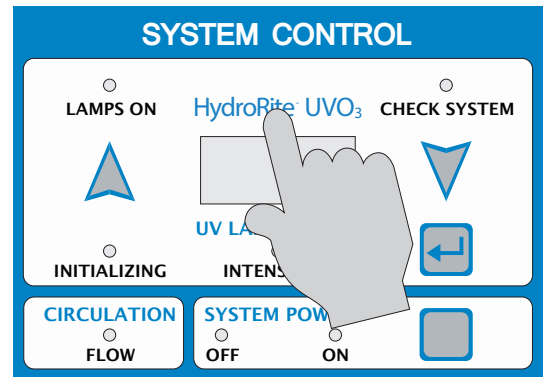
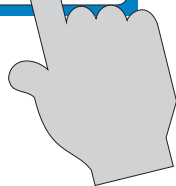

2) Access the Menu by holding the hidden button under the "Rite" in HydroRite.

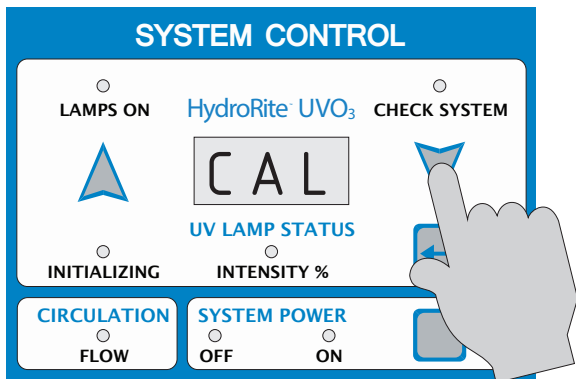

3) Push the arrow keys until "CAL" is shown in the display.

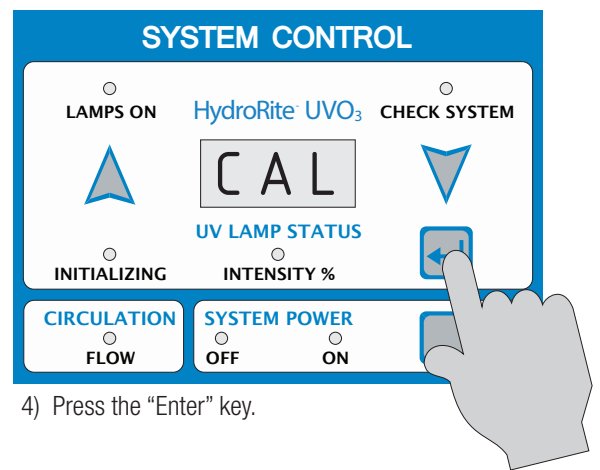

4) Press the "Enter" key.

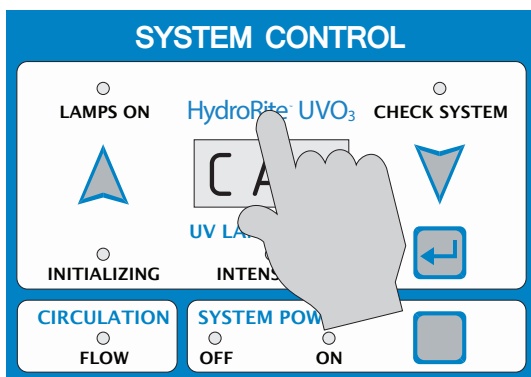

5) Exit menu by pressing the hidden "Rite" button.

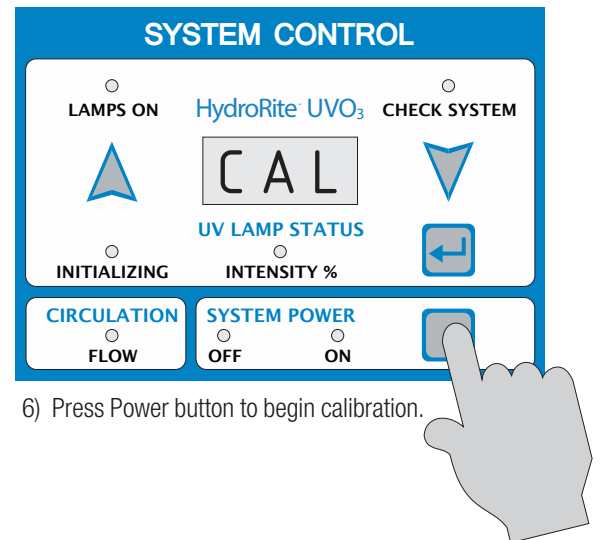

6) Press Power button to begin calibration.



## Maintenance

HydroRite has been designed for robust performance in the harsh environmental conditions of sun, wind, and rain. Like most pool equipment, routine maintenance will help provide years of trouble-free service. While HydroRite requires very little maintenance throughout the year, inorganic and organic chemicals may deposit on the surface of the quartz sleeve causing reduction of its germicidal UV (254nm wavelength light) transmittance and ultimately, the need for cleaning. HydroRite has a built-in alarm which will indicate low performance usually due to a dirty quartz sleeve. Cleaning the sleeve should return HydroRite to previous performance.

Also note that the UV bulbs have a defined life and degrade over time. If HydroRite continues to indicate and alarm after cleaning the quartz sleeve, the UV bulbs may need to be replaced. **IMPORTANT: Calibration should only take place after lamps have been replaced. Never calibrate during normal operation or after cleaning the quartz sleeves.**

The quartz sleeve can be cleaned in one of two ways. Manually disassembling and removing the sleeve or using a in-line automatic cleaner.

### Automatic Cleaning of the Quartz Sleeve

When using an automatic cleaner, the HydroRite's quartz sleeve can be cleaned with no need to disassemble the vessel. When the user initiates a cleaning, an acid bath will clean the quartz sleeve. The cleaner is connected to the inlet and outlet ports located on the top and bottom sides of the vessel only when cleaning, then disconnected during normal operation. If automatic cleaning will be employed, three way valves are required to isolate the HydroRite vessel from the pool's plumbing. Refer to your automatic cleaner for cleaning instructions.

**Muriatic Acid:** Use a diluted mixture of 4 parts water to 1 part Muriatic acid (20° Baume hydrochloric acid 31.45% by weight). Always add acid to water, and do so slowly.

### Disposing of Acid

Follow the manufacturer's instructions on how to properly dispose of the Muriatic Acid mixture.

### Manual Cleaning of the Quartz Sleeve

To remove and clean the quartz sleeve, follow the steps shown below:

**CAUTION:** The UV lamp is sensitive to handling and should be allowed to fully cool before being moved. Wait at least 30 minutes after disconnecting power to begin the removal process.

#### 1. Disconnect Power

Unplug the device from its Power Outlet.

#### 2. Stop the Pool Filter Pump

You must shut off the filter pump so that no water is flowing into the vessel. When you are absolutely sure that there remains no pressure inside the HydroRite vessel, you can proceed to the next step.

#### 3. Drain the HydroRite System

You must drain the unit before any internal maintenance is performed. To drain, unscrew the threaded plug from the base of the vessel. NOTE: If the Acid Wash system is plumbed, remove the hose to the shut-off valve from the base of the vessel. You can then open the valve to release the pool water.

#### 4. Remove the Electrical Enclosure Cover

NEVER REMOVE THE VESSEL CAP WITHOUT FIRST UNPLUGGING THE CONTROLLER FROM ITS POWER SOURCE – DO NOT OPERATE THE UNIT WITH THE CAP REMOVED - The vessel cap is removed by unscrewing the four mounting screws that hold the cap to the HydroRite vessel.

#### 5. Remove the UV sensor cable

Unscrew the sensor cable from the center of the vessel top.

#### 6. Remove the UV Lamp using supplied gloves

To remove the lamp, grasp the lamp connector (at end of ballast cable) and rotate counter-clockwise (about 1/8 turn) to unlock the lamp from the vessel. Once unlocked, slowly pull the lamp straight up and away from the quartz sleeve until it clears the vessel. **DO NOT TOUCH THE UV LAMP WITH YOUR BARE HANDS!** Oils from your hands can attach to the lamp surface and create hot spots during operation and shorten lamp life. Use a soft clean cotton cloth or supplied gloves to handle the lamp. Carefully place the lamp in a safe location.

NOTE: If you should touch the lamp with your bare hands, it can be cleaned with a soft cotton cloth and rubbing alcohol.

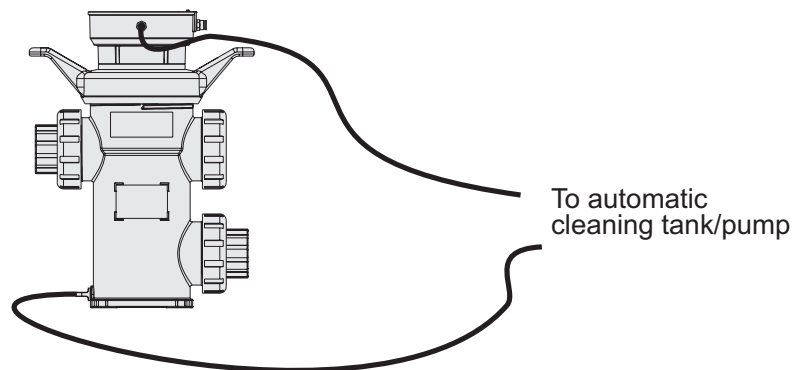

**7. Unscrew the Vessel Lock Nut**

Grasp the two large “handles” on the vessel lock nut and fully unscrew (counterclockwise) the light engine.

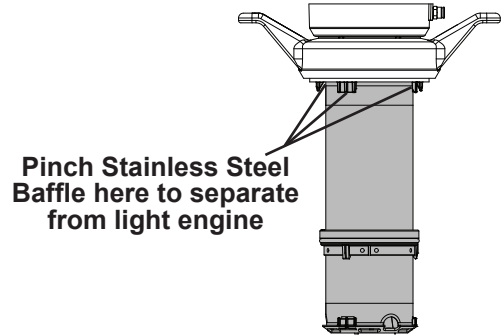
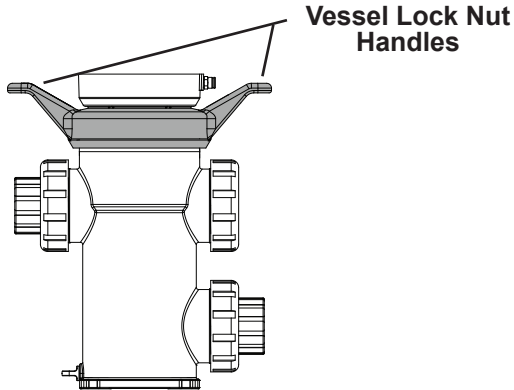

**8. Pull the Light Engine out of the Vessel**

Using the handles on the vessel lock nut, lift the light engine straight up and out of the vessel.

**9. Remove the Stainless Steel Baffle**

There is a stainless steel baffle that surrounds the quartz sleeve which must be removed. To remove the baffle, there are three fastening points which must be released. Pinching the baffle at those points will flex the surface enough to “unhook” the baffle from the light engine. Pinch one point at a time until all three are unhooked.

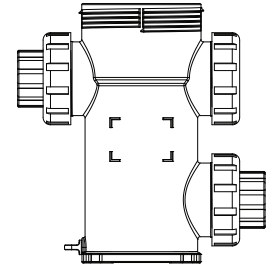

**10. Cleaning the Quartz Sleeve**

The quartz sleeve will now be exposed and can be cleaned. Note that the inside of the quartz sleeve is normally sealed and should never need cleaning. Carefully clean the outside of the quartz sleeve using NON-ABRASIVE CLEANERS, as they can scratch the high quality glass. If lime or hard water calcium deposits are encountered, rinse the quartz sleeve with tap water, then clean with lime removal products such as Lime-A-Way® or a Muriatic acid. Use appropriate eye protection and gloves when handling harsh chemicals. A lint free cloth can be used to help wipe away deposits. After using the lime removal products, rinse and wipe with the sleeve with rubbing alcohol. Completely dry the sleeve before re-assembly.

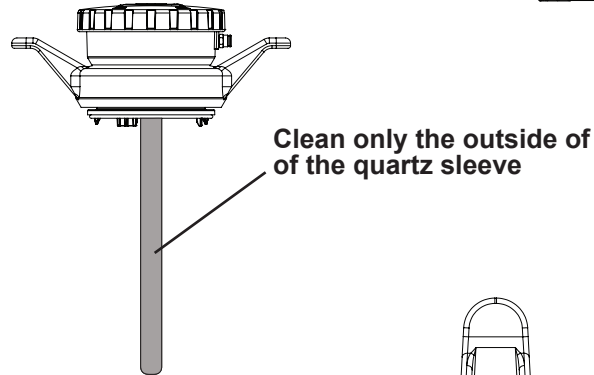

Carefully inspect the cleaned quartz sleeve for cracks. If any cracks in the quartz sleeve are found, the sleeve should be replaced. A broken quartz sleeve will allow water to enter the dry electrical chamber and attack the electrical components of the unit, which will cause them to fail and need to be replaced. Dispose of any broken glass in the proper waste receptacle. **BROKEN QUARTZ SLEEVES, OR WATER DAMAGE CAUSED BY BROKEN QUARTZ SLEEVES, ARE NOT COVERED UNDER YOUR LIMITED WARRANTY.**

**11. Cleaning the UV Sensor**

Over time, a thin milky film may coat the UV sensor tip. Use a lint free cloth with a little bit of isopropyl alcohol to gently clean the white UV sensor tip (shown right). Be careful, scratching the sensor tip can cause a malfunction in operation.

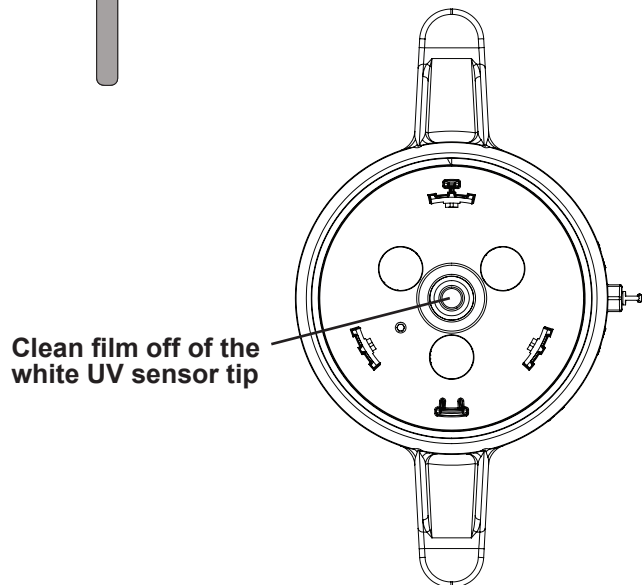

**12. Reinstall the Stainless Steel Baffle**

The easiest way to reinstall the baffle is to place it end up on the ground and lower the light engine on top of it. Guide the baffle making sure that the 3 locking tabs on the light engine line up with the 3 slots in the baffle. Gently push the light engine down until the baffle snaps into place.



### 13. Insert the Light Engine into the Vessel and Fasten with the Vessel Lock Nut

The light engine must be oriented in a certain position for it to fully insert into the vessel. Lower the light engine until the final 1" or so and look for the two slots on the inside top of the vessel. Spin the light engine until the two keys line up with the slots. Now fully push the light engine down into the vessel and lock by tightening the vessel lock nut.

### 14. Reinstall the UV lamp.

Slowly lower the lamp down into the quartz sleeve and twist clockwise to lock.

### 15. Reinstall the Sensor Cable

Screw the sensor cable into the center of the vessel top as shown in the diagram on page 7.

### 16. Reinstall the Vessel Cap

Place the vessel cap on the top of the HydroRite unit and tighten the screws using a Phillips screwdriver. DO NOT over tighten the screws due to risk of cracking the cover. Turn on the filter pump, making sure to open any valves (if applicable) that were closed. Verify that there are no leaks before powering the HydroRite.

## Scheduled UV Lamp Replacement

In addition to cleaning of the quartz sleeve, periodic replacement of the UV lamp is required. The High Output UV lamp in your HydroRite unit is designed to last for more than 16,000 hours of continuous operation. The HydroRite will show relative intensity and will sound an audible alarm when the intensity falls below 70%. This low intensity could be caused by a dirty quartz sleeve or could be due to a worn lamp. Try cleaning the sleeve and determine if that was the cause. If replacing the lamp, clean the quartz sleeve at the same time to minimize your maintenance efforts. For convenience, a log sheet has been placed on 17 to aid in the cleaning and lamp replacement schedule.

## Winterizing

Your HydroRite unit can be damaged if not properly winterized. Ice formation inside the vessel can break the glass quartz sleeve, the UV lamp or the vessel itself. Therefore, you must protect your HydroRite unit from freezing. Damage due to freezing, including the breakage of glass components, the vessel, or water damage to other components caused by freezing IS NOT COVERED under your Limited Warranty. During winterization, drain your UV device of all water within the vessel and venturi—use a Wet-Dry vacuum if necessary. Store the sleeve and lamp and all connectors in a manner to prevent breakage or corrosion during the winter months.

## Freeze damage

Freeze damage can be avoided by keeping the water flowing at a minimum of 5 PSI pressure (as noted on the pressure gauge) at all times, without interruption during freezing weather. All filter pump timers must be inoperable and the filter pump must run continuously. Freeze damage can also be avoided if the filter pump and HydroRite unit are maintained inside a climate controlled enclosure. If you do not plan to operate your HydroRite unit during freezing temperatures, you must take precautions to make sure all water is removed from inside the HydroRite vessel so it does not freeze. This can be accomplished by first closing any valves on lines in the plumbing system and then opening the inlet union at the bottom of the HydroRite unit so that the water can drain.

## How To Obtain Service

In the event that service is required, contact your builder or dealer so they can advise the best method of providing the services you need. In some instances, the supplier will handle the required service themselves, including the ability to supply any necessary parts. In other instances, the supplier will refer you to Hayward, who can assist you as well. Please read the Limited Warranty in this manual for your HydroRite unit. It explains fully what is and what is not covered under the Limited Warranty and the warranty periods.

## FAQs

Q. *Is HydroRite compatible with ALL Pool chemicals?*

A. YES, except for a biguanide sanitizer. The strong oxidizing power of the HydroRite device will destroy the biguanide chemical, rendering the water a milky white color.

Q. *Is There Any Residual Effect From UV?*

A. NO, UV light is applied only to the water while it passes through the HydroRite vessel. For this reason, a chemical sanitizer such as bromine or chlorine is still required; however, the levels of these sanitizers can be reduced by as much as 75% over typical levels

Q. *Is the HydroRite System Designed For Salt Water Use?*

A. YES, all plastic components are compatible with pools equipped with Hayward Salt Chlorine Generator Systems. The stainless steel insert sleeve will slowly deteriorate in salt water. The sleeve can be replaced easily as it slides into the vessel.

Q. *Do I Need To Turn HydroRite Off When I Clean My Filter?*

A. NO, the flow sensing pressure switch that is part of your HydroRite unit will automatically shut the UV lamp off until proper water flow inside the HydroRite unit is re-established. Should you need to turn your unit off for any reason, this is accomplished by simply unplugging the HydroRite unit from its power outlet.



# HAYWARD®

- Q. *Will A Time Clock On My Pool Shorten My Lamp Life?*  
A. MAYBE, Some shortening of the lamp life can be expected when the HydroRite unit is turned off and back on frequently. However, a daily on/off cycle will not create a major lamp life issue. Frequent on/off cycles should be avoided, however. For best lamp efficiency, the lamp should be replaced on yearly basis.
- Q. *Can the HydroRite Unit Be Mounted Horizontally?*  
A. NO, vertical mounting is required to maintain the proper flow dynamics inside the vessel for maximum exposure to the UV light. Also, the unit has been designed for maximum weather integrity of the electronics when mounted vertically.
- Q. *Can Multiple Units Be Used Together For Larger Systems?*  
A. YES, you can add any number of HydroRite units to a manifold system to allow for larger outputs and flow rates beyond the capacity of a single HydroRite unit. Contact Hayward to obtain a drawing showing the proper method of plumbing multiple HydroRites for larger applications.
- Q. *Why is my lamp intensity reading lower approximately a week or two after calibration?*  
A. The UV lamps will experience a burn-in period when new and it is normal for the intensity to drop 2 - 3% after the first 100 hours of use.
- Q. *Why do I see bubbles going into the pool?*  
A. This is perfectly normal and expected. The HydroRite unit draws ozone containing air into the pool plumbing through a venturi where it then enters the vessel and is converted to potent hydroxyl radicals. These radicals last but a mere fraction of a second. The remaining air (with no ozone) is sent back to the pool. The bubbles returning to the pool is just air and is harmless to bathers and equipment.
- Q. *The HydroRite needs to be cleaned shortly after installation, is this normal?*  
A. In some case, we have seen a need to clean the quartz sleeves inside the vessel after the first week or two of operation. This occurs as a result of oils and other organics in the water and typically resolves itself after the first cleaning. Periodic cleaning will be necessary but typically not at this frequency.

## Status Codes

A list of HydroRite status codes are shown below. These codes can warn of problems with the system as well as displaying the operational status.

<b>Cal</b>	Indicates that the HydroRite is in CALIBRATION mode (alternates with minutes remaining)
<b>OF</b>	Indicates that the lamp is OFF
<b>P</b>	The HydroRite has completed calibration successfully
<b>F</b>	The HydroRite has failed the calibration procedure (can fail for high temperature or no flow conditions)
<b>FLO</b>	A no flow condition or a high temperature condition exists
<b>SyS or Err</b>	A system error has occurred because the lamp intensity has fallen below 70% of maximum value
<b>tEP</b>	A high temperature condition exists in the controller

## Troubleshooting

The information below will help guide you through any problems you may have at time of initial installation or during operation. For additional assistance, contact your supplier or Hayward.

### The UV Lamps Will Not Light at Start-up

If this occurs upon initial start-up:

- The lamp has become disconnected from the 4-pin connector. Disconnect the power cord from the electrical outlet, open the electrical enclosure cover and confirm the lamp connector is firmly in place. At the same time, check all exposed wires for a possible loose connection. Plug the electrical cord back into the electrical outlet ONLY after the electrical enclosure cover has been reinstalled on the unit.
- Verify that the power cord is plugged into a properly functioning electrical outlet. Test the electrical outlet and make sure the GFCI has not tripped. You should confirm the availability of the same voltage as indicated on the electrical label on your HydroRite unit.
- Make sure you have not plugged your device into any power source other than that specified on your device's electrical label. If you have done so in error, the ballast has been damaged and needs to be replaced. Contact your supplier or Hayward for the correct replacement ballast. A replacement ballast is not warranted.





### The UV Lamps Are No Longer Lit

If this occurs after the unit has been operating successfully for a period of time:

- The lamp has burned out. Replace the UV lamp.
- The ballast has burned out. Contact your supplier or Hayward for assistance in obtaining a new ballast.
- Verify that the electrical outlet where the device is plugged into has the proper voltage and the cord is securely plugged into the outlet.
- Verify that the GFCI has not tripped. To verify the operating state of the GFCI, trip the GFCI manually and reset it manually. The GFCI should reset. If it does not, it indicates a fault to ground in the electrical circuit or the HydroRite unit itself. Call a certified electrician to fix the problem.
- The HydroRite Unit Makes Noise When Operating - This is an indication that the HydroRite unit is not properly attached to a firm mounting base. It can also indicate that the UV lamp was installed without the required lamp O-rings.
- The vessel cover has not been fully secured. Be sure the cover is aligned properly and the 4 screws are fully fastened.

### There is Water under the Vessel Cap

Water in contact with the electrical connectors can cause damage. If this occurs:

- The quartz sleeve seal is bad.
- The four screws securing the cap are not tight
- There is a broken or cracked quartz sleeve.

### Head Loss

The table below shows head loss information for the HYR2CSC-UVO.

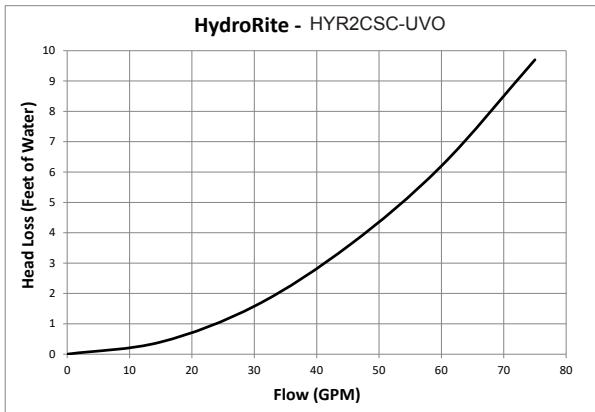

## Replacement Parts

Number	Part #	Description
1	HYX2CCPS	2" Commercial Controller UVO - Controller Only
2	HYX2C-XFMR	2" Commercial Power Transformer - 250 VAC
3	HYX2CFK25	Fuse Kit for 2" Commercial Interconnect PCB - 10 Pack
4	HYX2CSIPCB	Interconnect PCB for 2" Commercial Controller
5	HYXSBCBA	Ballast and Cable Harness for 2" Commercial Controller
6	HYXSDIAS	Digital Display and Keypad Assembly
7	HYXSPCBA	PCB Assembly for Digital Display Panel
8	HYXSSECA	Cable Assembly for UV sensor
9	HYXSFANA	Fan Assembly
10	HYXSLACA	Cable and Connectors for UV Lamp - Lamp Not Included
11	HYX2CVES-C	2" Commercial Vessel Body With Unions - UV
12	GLX-HYDSLEEVE	Stainless Steel Sleeve With O-Rings for 2" Commercial Vessel
13	HYX-MAN2	Ozone Manifold for 2" Commercial Vessel
14	HYX2DQSA	Quartz Sleeve Assembly for 2" Vessel UV Lamps
15	HYX2DLAS	2" Commercial Lamp, UV/03- Dual Wavelength
16	HYX2DLAS-3PK	2" Commercial Lamp, UV/03- Dual Wavelength-Pack of 3
17	HYX2DVEN-CK	Complete Venturi Kit for 2" Commercial Ststem - No Pump
18	HYX2DVEN-TM	Venturi Injector for 2" Commercial System - No Pump
19	HYX-HCPBP	1HP Venturi Booster Pump for Commercial System
20	HYX-HCPJB	Junction Box for Commercial Venturi Booster Pump
21	HYX2DVTA	Venturi Ozone Tube Assembly Kit
22	BSX1CAP2	2" Simplex PVC Port Cap - 2" Commercial Only
23	BSX1PLUG2	1" PVC Drain Plug
24	ECX12S	2" PVC Pipe Connector Socket - 2" Commercial Only
25	ECX12T	2" PVC Pipe Connector Threaded - 2" Commercial Only
26	SB2KIT	2" Vessel O-Ring Kit - 2" Commercial Only
27	TBX122	2" PVC TB NUT - 2" Commercial Only
28	CAX-20100	FUSE-.5 AMP
29	CAX-20101	FUSE-1 AMP
30	CAX-20102	FUSE-4 AMP
31	HYX2SUVSE	UV Sensor

\* Not Shown

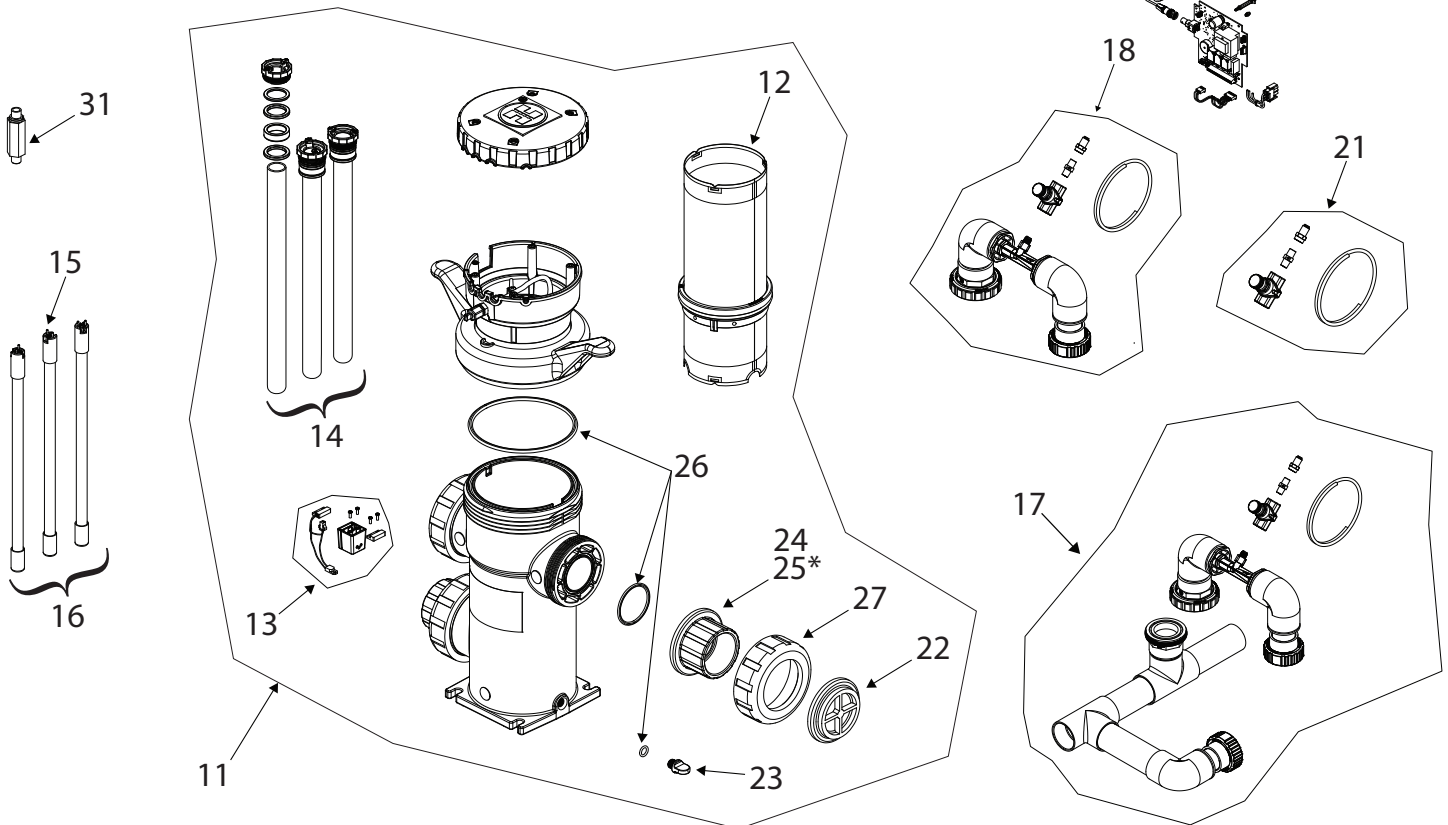
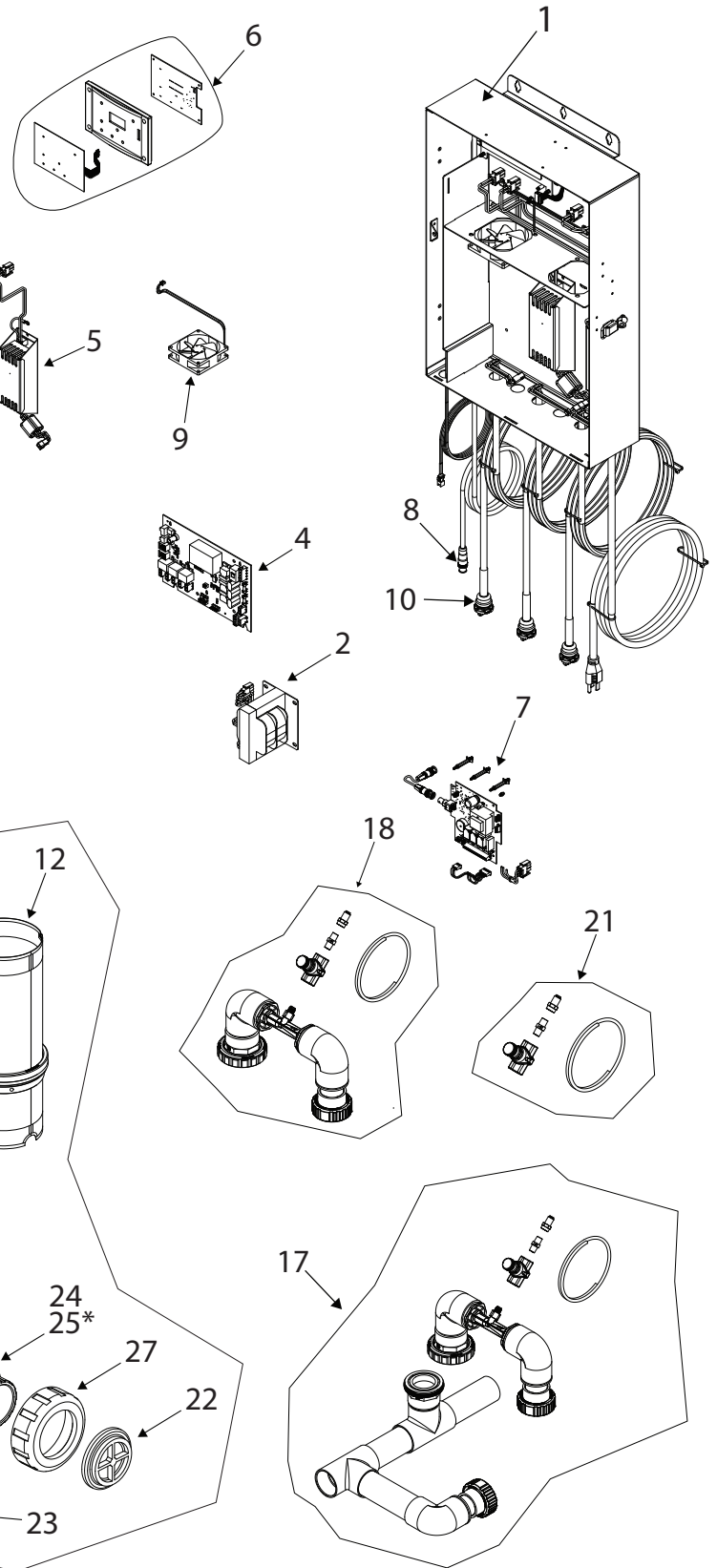



# HAYWARD®

## HydroRite Operations Log

Date Initial Install

Time Initial Install

Unit Serial Number

Company Who  
Installed and Contact  
Info

*This Log should be completed weekly, bi-weekly, or upon any system error display. Notes should be added for bulb failure, bulb replacement, parts failure, etc.*

Date	Time	Intensity Level Displayed	System Error Displayed(if any)	Bulb Cleaning Completed (Yes or No)	Type of Cleaning (Manual or Automatic)	Notes:

## HAYWARD® Pool Products Limited Warranty

To original purchasers of this equipment, Hayward Industries, Inc. warrants its HydroRite HYR2CSC-UVO to be free from defects in materials and workmanship for a period of Three (3) years from the date of purchase with the following exception. The UV lamps, UV sensor, Quartz sleeves and stainless steel sleeve carry a One (1) year warranty from the date of purchase.

Part	Warranty Period	Coverage
Controller	3 Years	Parts only
Vessel	3 years	Parts only
UV Lamp	1 Year	Parts only
UV Sensor	1 Year	Parts only
Quartz Sleeve	1 Year	Parts only
Stainless Steel Sleeve	1 Year	Parts only

The limited warranty excludes damage from freezing, negligence, improper installation, improper use or care or any Acts of God. Parts that fail or become defective during the warranty period shall be repaired or replaced, at our option, within 90 days of the receipt of defective product, barring unforeseen delays, without charge.

Proof of purchase is required for warranty service. In the event proof of purchase is not available, the manufacturing date of the product will be the sole determination of the purchase date.

To obtain warranty service, please contact the place of purchase or the nearest Hayward Authorized Service Center. For assistance on your nearest Hayward Authorized Service Center please visit us at [www.haywardpool.com](http://www.haywardpool.com).

Hayward shall not be responsible for cartage, removal, repair or installation labor or any other such costs incurred in obtaining warranty replacements or repair.

The Hayward Pool products warranty does not apply to components manufactured by others. For such products, the warranty established by the respective manufacturer will apply.

The express limited warranty above constitutes the entire warranty of Hayward Pool Products with respect to its pool products and is in lieu of all other warranties expressed or implied, including warranties of merchantability or fitness for a particular purpose. In no event shall Hayward Pool products be responsible for any consequential, special or incidental damages of any nature.

Some states do not allow a limitation on how long an implied warranty lasts, or the exclusion of incidental or consequential damages, so the above limitation may not apply to you. This warranty gives you specific legal rights, and you may also have other rights, which vary from state to state.

Hayward Pool Products, 620 Division Street, Elizabeth, NJ 07207

\*Supersedes all previous publications.



Hayward is a registered trademark and HydroRite is a trademark of Hayward Industries, Inc. © 2019 Hayward Industries, Inc.

All other trademarks not owned by Hayward are the property of their respective owners. Hayward is not in any way affiliated with or endorsed by those third parties.